



COLLECTION
VERRERIE 2026

CRÉATEUR
R
D'EXPÉRI-
ENCES



 **MartelCHR**
Les Arts de la Table

 04 94 69 89 00

 contact@martelchr.com

 ZAC de Nicopolis - BRIGNOLES



■	VERRE À PIED	P06
■	GOBELET	P52
■	COCKTAIL, CHAMPAGNE, BIÈRE & SPIRITUEUX	P66
■	CARAFE	P90
■	INFORMATION PRODUIT	P94

 Cliquez sur la page souhaitée

● ABONDANCE <i>new</i>	P92 / 95
● ABSOLUTY.....	P54 / 95
○ ARCHITECTE.....	P60-89 / 95
● BEER EXPERT <i>new</i>	P80 / 95
● CABERNET.....	P22-24-26-68 -81 / 95
● CHAMPAGNE&COCKTAIL.....	P70 / 95
● DISTINCTION.....	P28 / 95
● ÉVIDENCE.....	P30 / 95
● EXALTATION <i>new</i>	P14-72 / 95
● EXPLORE.....	P92 / 95
● GALEA <i>new</i>	P10 / 95
○ LADY DIAMOND.....	P42-61 -78 / 95
● LIMA.....	P55-82-88 / 96
○ LONGCHAMP.....	P44-61-79-89 / 96
● MACARON.....	P16-58-73-93 / 96
● MACARON FASCINATION.....	P71 / 96
○ MACASSAR.....	P46-63-79-89 / 96
● MYLLA <i>new</i>	P12 / 96
● OPENING.....	P93 / 96
● OPEN'UP.....	P18-58-73-81 -93 / 96
● OPEN'UP SPIRIT.....	P85 / 96
● PRIMARY.....	P58 / 96
● PRIMARY COLOR.....	P65 / 96
○ RENDEZ-VOUS.....	P48-63-79-89 / 97
● REVEAL'UP.....	P20-74-81 / 97
● SENSATION EXALT.....	P32-75 / 97
● SÉQUENCE.....	P34-75-87 / 97
● SPIRITS.....	P86 / 97
● SUBLYM.....	P36-76-81 / 97
○ SWIRLY <i>new</i>	P50-62-79 / 97
● SYMÉTRIE.....	P40-77 / 97
● VIGNE.....	P56-82-88 / 97
● VIN AU VERRE.....	P38 / 97

 Cliquez sur la page souhaitée

Ø M = Diamètre maximal H = Hauteur
 Ø W/O anse = Sans anse P = Poids

Tous les produits sont labellisés ORIGINE FRANCE GARANTIE,
 à l'exception des produits portant la mention ◆.



Arc est né dans le nord de la France, à Arques, où se trouvent toujours le siège du Groupe, son pôle Recherche et Développement et le plus grand site de production verrière dans le monde.

Solidement ancré en France et dans sa région d'origine, Arc fabrique et distribue ses produits sur tous les continents.

Le Groupe dispose de sites de production en Chine, aux Émirats Arabes Unis et aux États-Unis. Il rayonne à travers cinq marques (Arcopal™, Cristal d'Arques Paris™, Luminarc™, Arcoroc™ et Chef&Sommelier™) en mettant le beau à la portée de tous, partout dans le monde.

Chef&Sommelier

Chef&Sommelier™ est la marque héritière d'un art de vivre ancré dans la richesse de la gastronomie et de l'oenologie françaises.

Chef&Sommelier™ imagine des collections de verrerie aux lignes pures et élégantes.

Une signature unique au service des belles tables, des hôtes exigeants recherchant à sublimer leur savoir-faire, éveiller les sens et créer des expériences de dégustations inoubliables pour leur famille ou amis.

Les collections de Chef&Sommelier™ s'inscrivent dans un monde d'innovation, de passion, d'élégance et d'exigence.

Avec Chef&Sommelier™, place au plaisir, à la créativité, à la découverte et à l'authenticité partagée !

L'ensemble des articles de Chef&Sommelier™ sont produits en Krysta, un cristallin de nouvelle génération, en France, dans la région haut de France.

Chef&Sommelier™ est une marque du groupe ARC et bénéficie donc du savoir faire et de l'héritage de ce grand groupe industriel créé en 1825, et qui est devenu depuis le leader mondial des Arts de la table.

Aujourd'hui, Chef&Sommelier™ dévoile la collection EXTRA-THIN, l'unique cristallin extra-fin fabriqué en France.

CRISTAL D'ARQUES®

Depuis 1968, Cristal d'Arques Paris™ incarne l'élégance à la Française et le beau à la portée de tous.

Tout en restant fidèle à ses valeurs, la marque cultive désormais l'esprit chic décontracté en s'inspirant du courant Art déco et d'un art de vivre parisien.

S'appuyant sur son savoir-faire, Cristal d'Arques Paris™ se métamorphose en réinterprétant les codes du luxe de manière spontanée et actuelle.

VERRE À PIED



EXTRA-FIN

● Galea



P 10

● Mylla



P 12

EXPERT

● Exaltation



P 14

● Macaron



P 16

● Open'Up



P 18

● Reveal'Up Intense



P 21

● Reveal'Up Soft



P 20

UNIVERSEL

● Cabernet Abondant



P 22

● Cabernet Ballon



P 23

● Cabernet Suprême



P 22

● Cabernet Tulipe



P 24-26

● Cabernet Vins Jeunes



P 27

● Distinction



P 28

● Évidence



P 30

● Sensation Exalt



P 32

● Séquence



P 34

● Sublym



P 37

● Sublym Ballon



P 36

● Vin au verre



P 38

VERRE STRUCTURE

○ Lady Diamond



P 42

○ Longchamp



P 44

○ Macassar



P 46

○ Rendez-vous



P 48

○ Swirly



P 50

● Symétrie



P 40

● Chef&Sommelier

○ CRISTAL D'ARQUES®



Mylla



Nos verres subliment chaque vin et enrichissent l'art du service. Découvrez nos collections, chacune définie par une philosophie unique.



EXALTIATION pour les vins effervescents



OPEN'UP pour les vins jeunes



MACARON pour les vins bio



REVEAL'UP SOFT polyvalent, pour les vins effervescents, jeunes & mûres



REVEAL'UP INTENSE pour les vins puissants et charpentés



Découvrez nos collections brochure Les Experts

LES EXPERTS

Notre gamme Experts est le fruit de recherches approfondies sur la façon dont la forme du verre sublime les arômes. C'est le choix privilégié des professionnels qui souhaitent maîtriser chaque nuance de la dégustation de vin..



GALEA



MYLLA



Découvrez nos collections brochure L'Extra-Fin

L'EXTRA FIN

Notre collection Extra-Fins repousse les limites de la délicatesse pour une expérience inégalée. Leurs bords ultra-fins disparaissent, permettant au vin de glisser en douceur et d'exprimer tout son caractère..

Intemporels

Fonctionnels

Tendances



CABERNET BALLON



CABERNET TULIPE



SENSATION EXALT



ÉVIDENCE



CABERNET VINS JEUNES



SYMÉTRIE



SUBLYM



EXALTIATION



DISTINCTION



CHAMPAGNE COCKTAIL

LES UNIVERSELS

Nos verres Universels sont la solution idéale pour ceux qui recherchent la polyvalence. Leur forme équilibrée est conçue pour sublimer une grande variété de vins - rouges, blancs ou rosés, et pour offrir une durabilité remarquable et une élégance intemporelle.



Découvrez nos collections brochure Les Universels

Tous nos verres à pied sont conçus pour améliorer l'expérience de dégustation de tous les vins grâce aux avantages de notre Krysta™.



Galea

Galea

* EFFERVESCENCE PLUS

C&S KRYSTA

EXTRA-FIN

NEW



GALEA
65 cl
Ø M = 100 mm
H = 235 mm
P = 185 g
X2712



GALEA
55 cl
Ø M = 95 mm
H = 235 mm
P = 185 g
X2713



GALEA
47 cl
Ø M = 90 mm
H = 230 mm
P = 160 g
X2495



GALEA
38 cl
Ø M = 85 mm
H = 220 mm
P = 140 g
X2714



Mylla

Mylla

* EFFERVESCENCE PLUS

C&S **KRYSTA**
EXTRA-FIN**NEW**

MYLLA
65 cl
Ø M = 105 mm
H = 240 mm
P = 180 g
X2716



MYLLA
55 cl
Ø M = 95 mm
H = 245 mm
P = 180 g
X2717



MYLLA
47 cl
Ø M = 90 mm
H = 235 mm
P = 160 g
X2500



MYLLA
38 cl
Ø M = 85 mm
H = 225 mm
P = 140 g
X2718



EXPERT

Exaltation

C&S **KRYSTA**

* EFFERVESCENCE PLUS

BUVANT FIN



≈12,5 cl

EXALTATION
35 cl

Ø M = 80 mm
H = 235 mm
P = 155 g

Q0818



≈10 cl

EXALTATION
30 cl

Ø M = 80 mm
H = 210 mm
P = 150 g

Q1151

Q9945 coffret de 2

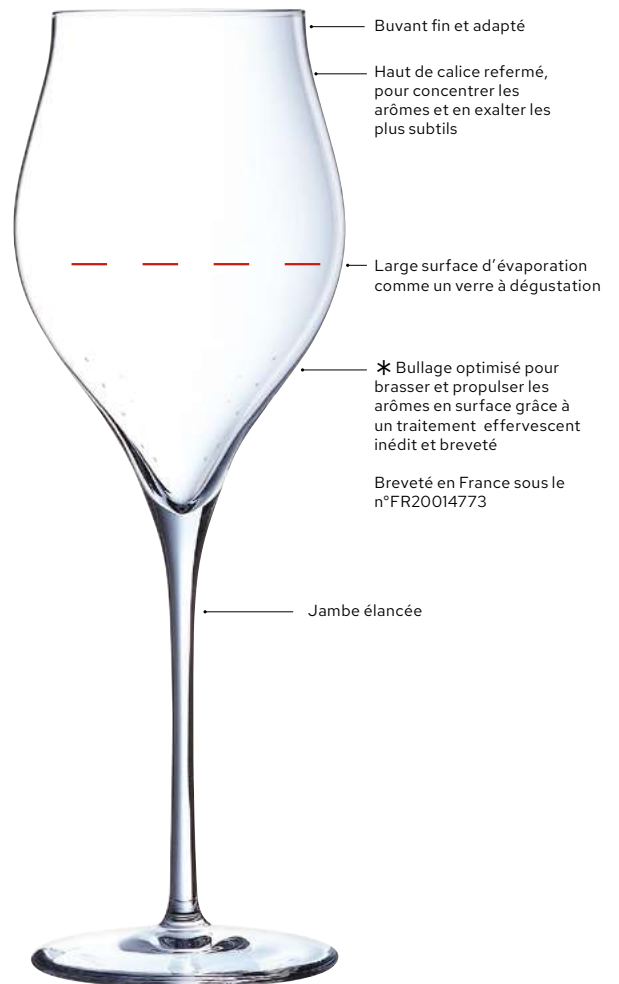

Exaltation



EXALTATION
75 cl

Ø M = 105 mm
H = 260 mm
P = 220 g

V6719 ◆



EXALTATION
55 cl

Ø M = 95 mm
H = 240 mm
P = 195 g

V6189



EXALTATION
47 cl

Ø M = 90 mm
H = 225 mm
P = 185 g

V6190

V6831 coffret de 2



EXALTATION
38 cl

Ø M = 85 mm
H = 215 mm
P = 165 g

V6191



Buvant fin,
pour plus de confort
lors de la dégustation

La forme Exaltation
pour les vins tranquilles.

Parfaite transparence pour
apprécier les robes des vins.
Rond et généreux pour une
bonne oxygénation des vins.
Un fond piqué pour une
silhouette élancée.

Jambe étirée

Pied large et plat,
plus de stabilité,
aucune rétention d'eau

*Flasher le QR-code
pour visualiser la vidéo,
ou cliquer directement
dessus pour la lancer !*



Macaron

C&S KRYSTA

BUVANT FIN



MACARON
40 cl FH

Ø M = 90 mm
H = 105 mm
P = 140 g

N0834 ◆

Macaron

C&S

SOUFFLÉ BOUCHE / TRAITEMENT ANTI-GOUTTE



MACARON
2 L

Ø M = 165 mm
H = 310 mm
P = 700 g

V6503 ◆

Macaron

Macaron

* EFFERVESCENCE PLUS

C&S **KRYSTA**

BUVANT FIN



≈ 19 cl

MACARON
60 cl

Ø M = 105 mm
H = 235 mm
P = 195 g

L9414 ◆

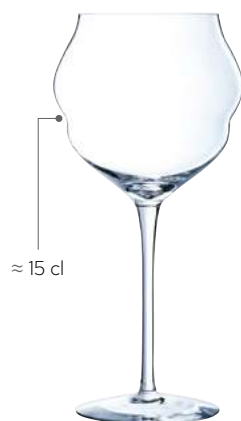

≈ 15 cl

MACARON
50 cl

Ø M = 100 mm
H = 215 mm
P = 165 g

L9412 ◆



≈ 12,5 cl

MACARON
40 cl

Ø M = 95 mm
H = 200 mm
P = 135 g

L9267 ◆

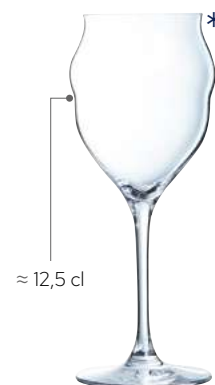

≈ 12,5 cl

MACARON
30 cl

Ø M = 85 mm
H = 200 mm
P = 130 g

L9348 ◆

Forme arrondie qui épouse
parfaitement la lèvre inférieure
pour un confort optimal

Haut du verre resserré
pour concentrer les arômes

Lecture facile du volume utile

2 coques de tailles différentes,
qui brassent le vin
et remonteront à la surface
les arômes les moins volatils

Design en rupture
pour différencier votre table



Découvrez le verre Macaron,
un "accélérateur de temps"



Flasher le QR-code
pour visualiser la vidéo,
ou cliquer directement
dessus pour la lancer!

Open'Up

C&S KRISTA

SOUFFLÉ BOUCHE / TRAITEMENT ANTI-GOUTTE

OPEN'UP
1,4 L

Ø M = 145 mm

H = 315 mm

P = 610 g

D 6653 ◆

Haut de la paraison
arrondi, concentration
des arômes

Angle prononcé
Les molécules du vin se
brisent et s'oxygènent
sur la cassure, libérant
ainsi les arômes

Jambe étirée
fluidité des lignes

Cuvette plate,
pas de rétention d'eau
au lave-vaisselle



Open'Up

Open'Up

* EFFERVESCENCE PLUS

C&S **KRYSTA**

BUVANT FIN

VERRE À PIED



≈ 11 cl

OPEN'UP
55 cl TANNIC

Ø M = 105 mm
H = 235 mm
P = 210 g

U1013



≈ 9,5 cl

OPEN'UP
47 cl SOFT

Ø M = 105 mm
H = 225 mm
P = 210 g

U1012

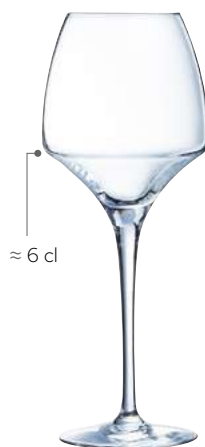

≈ 6 cl

OPEN'UP
40 cl UNIVERSAL TASTING

Ø M = 90 mm
H = 230 mm
P = 200 g

U1011

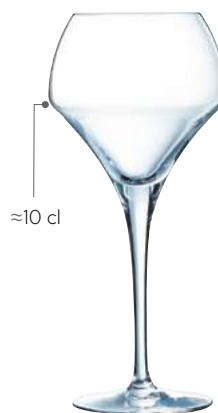

≈ 10 cl

OPEN'UP
37 cl ROUND

Ø M = 95 mm
H = 210 mm
P = 170 g

U1010



≈ 4 cl

OPEN'UP
32 cl PRO TASTING

Ø M = 85 mm
H = 180 mm
P = 135 g

U1008



≈ 12,5 cl

OPEN'UP
20 cl

Ø M = 75 mm
H = 235 mm
P = 165 g

U1051



OPEN'UP
35 cl FH

Ø M = 80 mm
H = 120 mm
P = 150 g

U1041



OPEN'UP
38 cl FB

Ø M = 95 mm
H = 95 mm
P = 160 g

U1033



Reveal'Up

C&S KRYSTA

* EFFERVESCENCE PLUS

BUVANT FIN



REVEAL'UP
21 cl

Ø M = 70 mm
H = 235 mm
P = 155 g

J8907



MACARON
40 cl FH

Ø M = 90 mm
H = 105 mm
P = 140 g

N0834 ♦

Cheminée pour réduire la perception d'alcool (au nez) et d'acidité (en bouche)

Angle doux permettant l'oxygénation des vins jeunes et révélant les arômes des vins matures

Lecture facile du volume utile

Jambe étirée sans couture
Très léger, excellent équilibre en main

Pied extra large, parfaite stabilité

Reveal'Up

Reveal'Up

* EFFERVESCENCE PLUS

C&S **KRYSTA**

BUVANT FIN

VERRE À PIED

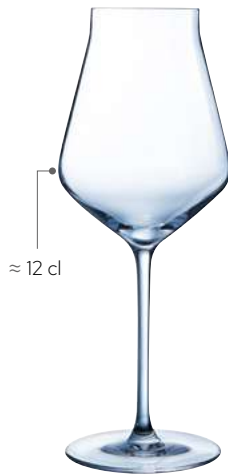

≈ 12 cl

REVEAL'UP
50 cl SOFT

Ø M = 95 mm
H = 245 mm
P = 200 g
N1738

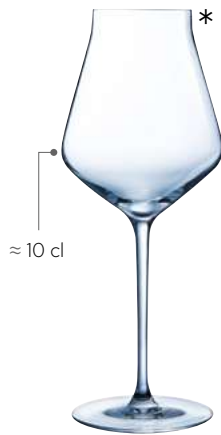

≈ 10 cl

REVEAL'UP
40 cl SOFT

Ø M = 90 mm
H = 230 mm
P = 195 g
J8743



≈ 7 cl

REVEAL'UP
30 cl SOFT

Ø M = 85 mm
H = 215 mm
P = 140 g
J8908

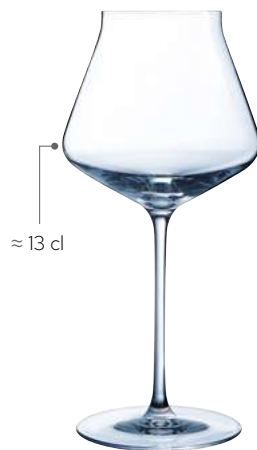

≈ 13 cl

REVEAL'UP
55 cl INTENSE

Ø M = 110 mm
H = 235 mm
P = 200 g
J9014



≈ 10 cl

REVEAL'UP
45 cl INTENSE

Ø M = 105 mm
H = 220 mm
P = 190 g
J8742



Paraison rétrécie pour une meilleure concentration des arômes

Surface d'oxygénation et chambre aromatique extra larges permettant le développement des arômes

Jauge naturelle

Jambe fine et élégante Très léger, excellent équilibre en main

Cuvette extra large, parfaite stabilité



Cabernet Abondant C&S KRYSTA

BUVANT FIN

CABERNET ABONDANT
70 cl

Ø M = 110 mm
H = 220 mm
P = 260 g

X2353 ◆CABERNET ABONDANT
50 cl

Ø M = 100 mm
H = 200 mm
P = 220 g

X2250 ◆

Cabernet Suprême C&S KRYSTA

BUVANT FIN

CABERNET SUPRÊME
62 cl

Ø M = 95 mm
H = 240 mm
P = 260 g

X2356 ◆CABERNET SUPRÊME
47 cl

Ø M = 85 mm
H = 215 mm
P = 220 g

X2358 ◆

Cabernet Suprême



CABERNET BALLON
70 cl

Ø M = 115 mm
H = 220 mm
P = 270 g

X2038



CABERNET BALLON
58 cl

Ø M = 105 mm
H = 210 mm
P = 240 g

X2059



CABERNET BALLON
47 cl

Ø M = 100 mm
H = 195 mm
P = 190 g

X2067



CABERNET BALLON
35 cl

Ø M = 90 mm
H = 180 mm
P = 190 g

X2050





CABERNET TULIPE
75 cl

Ø M = 100 mm
H = 255 mm
P = 230 g

X2049



CABERNET TULIPE
25 cl

Ø M = 70 mm
H = 180 mm
P = 150 g

X2056

Cabernet Tulipe

C&S **KRYSTA**

BUVANT FIN

VERRE À PIED



CABERNET TULIPE
58 cl
Ø M = 95 mm
H = 230 mm
P = 230 g
X2054



CABERNET TULIPE
47 cl
Ø M = 90 mm
H = 220 mm
P = 200 g
X2033



CABERNET TULIPE
35 cl
Ø M = 80 mm
H = 205 mm
P = 185 g
X2055
Existe dans la collection
VIN AU VERRE (p39)



CABERNET TULIPE
19 cl
Ø M = 65 mm
H = 165 mm
P = 145 g
X2064



CABERNET TULIPE
12 cl
Ø M = 55 mm
H = 150 mm
P = 105 g
X2036



CABERNET TULIPE
7 cl
Ø M = 50 mm
H = 135 mm
P = 80 g
X2360 ♦

Haut du verre refermé
pour concentrer
les arômes

Calice
tout en rondeur

Cuvette plate et stable,
pas de rétention d'eau
au lave-vaisselle

Cabernet Tulipe C&S KRISTA

* EFFERVESCENCE PLUS

BUVANT FIN

CABERNET
47 clØ M = 80 mm
H = 190 mm
P = 240 g**X2065**CABERNET
40 clØ M = 80 mm
H = 170 mm
P = 195 g**X2057**CABERNET
24 clØ M = 70 mm
H = 235 mm
P = 140 g**X2066**CABERNET
16 clØ M = 70 mm
H = 225 mm
P = 145 g**X2053**



≈19 cl

CABERNET VINS JEUNES
58 cl

Ø M = 105 mm
H = 225 mm
P = 210 g

X2035



≈15 cl

CABERNET VINS JEUNES
47 cl

Ø M = 100 mm
H = 215 mm
P = 190 g

X1720



≈10 cl

CABERNET VINS JEUNES
35 cl

Ø M = 90 mm
H = 200 mm
P = 165 g

X2034

Existe dans la collection
VIN AU VERRE (p39)



Bord fin,
sensation agréable
contre les lèvres

Large surface
d'oxygénation favorisant
le développement des arômes

Angle prononcé permettant
aux molécules du vin de s'oxygéner
et de bonifier lors de l'agitation

Cuvette plate et stable,
pas de rétention d'eau
au lave-vaisselle



Distinction



Distinction

* EFFERVESCENCE PLUS

C&S KRYSTA

BUVANT FIN



DISTINCTION
47 cl

Ø M = 95 mm
H = 235 mm
P = 185 g

Q9064



DISTINCTION
38 cl

Ø M = 90 mm
H = 220 mm
P = 175 g

Q9062



DISTINCTION
28 cl

Ø M = 85 mm
H = 210 mm
P = 150 g

Q8990



DISTINCTION
23 cl

Ø M = 70 mm
H = 235 mm
P = 130 g

Q9080



Évidence

Évidence

* EFFERVESCENCE PLUS

C&S KRYSTA

BUVANT FIN



ÉVIDENCE
45 cl

Ø M = 85 mm
H = 210 mm
P = 180 g

X2068



ÉVIDENCE
35 cl

Ø M = 80 mm
H = 190 mm
P = 140 g

X2042



ÉVIDENCE
27 cl

Ø M = 75 mm
H = 180 mm
P = 120 g

X2058



ÉVIDENCE
16 cl

Ø M = 65 mm
H = 190 mm
P = 140 g

X2063





UNIVERSEL

Sensation Exalt

C&S KRYSTA

* EFFERVESCENCE PLUS

BUVANT FIN



SENSATION EXALT
19 cl

Ø M = 70 mm

H = 210 mm

P = 170 g

X2048

Sensation Exalt

SOMMAIRE





SENSATION EXALT
41 cl
Ø M = 90 mm
H = 205 mm
P = 270 g
X2047



SENSATION EXALT
31 cl
Ø M = 80 mm
H = 200 mm
P = 220 g
X1722



SENSATION EXALT
25 cl
Ø M = 75 mm
H = 190 mm
P = 165 g
X2046



SENSATION EXALT
20 cl
Ø M = 70 mm
H = 180 mm
P = 160 g
X2040

Buvant fin,
haut de calice refermé

Angle peu prononcé,
capable d'aérer un vin jeune
et préserver un vin mûre

Jambe très résistante,
parfaitement adaptée
aux usages intensifs

Cuvette plate et stable,
pas de rétention d'eau au lave-vaisselle



Séquence

C&S KRISTA

* EFFERVESCENCE PLUS

BUVANT FIN



SÉQUENCE
17 cl

Ø M = 70 mm
H = 210 mm
P = 135 g

L9947



SÉQUENCE
24 cl IMPÉRIALE

Ø M = 70 mm
H = 235 mm
P = 155 g

P3787



SÉQUENCE
74 cl
Ø M = 100 mm
H = 235 mm
P = 200 g
L9951 ◆



SÉQUENCE
62 cl
Ø M = 95 mm
H = 235 mm
P = 210 g
N9710 ◆



SÉQUENCE
55 cl
Ø M = 90 mm
H = 235 mm
P = 190 g
L9950



SÉQUENCE
44 cl
Ø M = 90 mm
H = 225 mm
P = 180 g
L9949



SÉQUENCE
35 cl
Ø M = 80 mm
H = 210 mm
P = 155 g
L9948



Calice généreux qui concentre les arômes et permet une attaque en bouche bien précise

Jambe courte et pratique

Cuvette plate et stable, pas de rétention d'eau au lave-vaisselle



SÉQUENCE
21 cl PORTO
Ø M = 65 mm
H = 190 mm
P = 115 g
N9696 ◆



SÉQUENCE
37 cl BIÈRE
Ø M = 80 mm
H = 150 mm
P = 130 g
P0089 ◆



SÉQUENCE
47 cl MULTI-USAGE
Ø M = 85 mm
H = 180 mm
P = 165 g
N9711 ◆





SUBLYM
60 cl BALLON
Ø M = 110 mm
H = 230 mm
P = 210 g
N4742



Le vin, agité,
monte de façon verticale
exprimant les arômes en
couches successives

Continuité parfaite
du profil du verre

Cuvette plate et stable,
pas de rétention d'eau
au lave-vaisselle





SUBLYM
55 cl
Ø M = 90 mm
H = 260 mm
P = 220 g
V3604



SUBLYM
45 cl
Ø M = 90 mm
H = 250 mm
P = 210 g
N1739



SUBLYM
35 cl
Ø M = 80 mm
H = 230 mm
P = 175 g
L2761



SUBLYM
25 cl
Ø M = 70 mm
H = 210 mm
P = 150 g
L2609



SUBLYM
21 cl
Ø M = 65 mm
H = 240 mm
P = 140 g
L2762



SUBLYM
35 cl MULTI-USAGE
Ø M = 80 mm
H = 180 mm
P = 175 g
N5368





Vin au verre

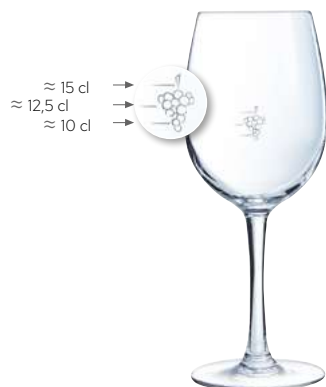
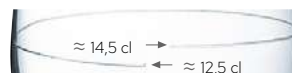

VIN AU VERRE
35 cl CABERNET TULIPE GRAPPE

Ø M = 80 mm
H = 205 mm
P = 185 g

X3043



VIN AU VERRE
35 cl CABERNET TULIPE ELLIPSE

Ø M = 80 mm
H = 205 mm
P = 185 g

X3045



VIN AU VERRE
35 cl CABERNET VINS JEUNES GRAPPE

Ø M = 90 mm
H = 200 mm
P = 165 g

X3042

Symétrie

C&S KRYSTA

* EFFERVESCENCE PLUS

BUVANT FIN



SYMÉTRIE
21 cl

Ø M = 115 mm
H = 180 mm
P = 170 g

V1171



Symétrie

Symétrie

* EFFERVESCENCE PLUS

C&S **KRYSTA**

BUVANT FIN

VERRE À PIED



SYMÉTRIE
58 cl

Ø M = 105 mm
H = 210 mm
P = 240 g

Q8707



SYMÉTRIE
21 cl

Ø M = 65 mm
H = 240 mm
P = 140 g

V2697



SYMÉTRIE
16 cl

Ø M = 65 mm
H = 200 mm
P = 130 g

V1375



SYMÉTRIE
55 cl

Ø M = 90 mm
H = 260 mm
P = 220 g

V2696



SYMÉTRIE
45 cl

Ø M = 90 mm
H = 250 mm
P = 210 g

V0391



SYMÉTRIE
35 cl

Ø M = 80 mm
H = 230 mm
P = 180 g

V1483





Lady Diamond

LADY DIAMOND
36 cl FH

Ø M = 70 mm
H = 130 mm
P = 400 g

L9746**V5468** coffret de 4LADY DIAMOND
27 cl FB

Ø M = 90 mm
H = 90 mm
P = 270 g

L9747**V4485** coffret de 4



LADY DIAMOND
27 cl

Ø M = 90 mm
H = 210 mm
P = 360 g

L9743

V4483 coffret de 4



LADY DIAMOND
19 cl

Ø M = 80 mm
H = 200 mm
P = 310 g

L9744

V4484 coffret de 4



LADY DIAMOND
15 cl

Ø M = 75 mm
H = 230 mm
P = 290 g

L9742

V8228 coffret de 4



NEW

LADY DIAMOND
23 cl

Ø M = 100 mm
H = 180 mm
P = 300 g

X1718 coffret de 4





Longchamp



LONGCHAMP
25 cl

Ø M = 75 mm
H = 180 mm
P = 305 g

L7550

V4704 coffret de 4



LONGCHAMP
17 cl

Ø M = 70 mm
H = 165 mm
P = 235 g

L7552

V4702 coffret de 4



LONGCHAMP
6 cl

Ø M = 49 mm
H = 115 mm
P = 95 g

L 9754



LONGCHAMP
14 cl

Ø M = 65 mm
H = 205 mm
P = 270 g

L7553

V4705 coffret de 4



LONGCHAMP
36 cl FH

Ø M = 80 mm
H = 135 mm
P = 410 g

L9757

V7383 coffret de 4



LONGCHAMP
28 cl FH

Ø M = 65 mm
H = 130 mm
P = 300 g

L7554

V7384 coffret de 4



LONGCHAMP
32 cl FB

Ø M = 56 mm
H = 95 mm
P = 290 g

L7555

V4700 coffret de 4



LONGCHAMP
23 cl FB

Ø M = 75 mm
H = 90 mm
P = 240 g

L9758

V7385 coffret de 4



LONGCHAMP
4,5 cl FB HOT SHOT

Ø M = 26 mm
H = 57 mm
P = 70 g

L9756



MACASSAR
36 cl FH

Ø M = 85 mm
H = 130 mm
P = 440 g

Q4340
V7376 coffret de 4



MACASSAR
32 cl FB

Ø M = 95 mm
H = 100 mm
P = 430 g

Q4337
V7377 coffret de 4



MACASSAR
6 cl FB

Ø M = 50 mm
H = 80 mm
P = 120 g

Q4342



MACASSAR
35 cl

Ø M = 95 mm
H = 210 mm
P = 300 g

Q4331

V7374 coffret de 4



MACASSAR
25 cl

Ø M = 85 mm
H = 200 mm
P = 250 g

Q4346

V7375 coffret de 4



MACASSAR
17 cl

Ø M = 60 mm
H = 235 mm
P = 210 g

Q4335

V7373 coffret de 4





Rendez-vous



RENDEZ-VOUS
36 cl FH
Ø M = 85 mm
H = 130 mm
P = 435 g
V7381 coffret de 4



RENDEZ-VOUS
32 cl FB
Ø M = 90 mm
H = 95 mm
P = 390 g
V7382 coffret de 4



RENDEZ-VOUS
35 cl

Ø M = 95 mm
H = 215 mm
P = 405 g

V7379 coffret de 4



RENDEZ-VOUS
25 cl

Ø M = 85 mm
H = 200 mm
P = 260 g

V7380 coffret de 4



RENDEZ-VOUS
17 cl

Ø M = 65 mm
H = 220 mm
P = 260 g

V7378 coffret de 4





Swirly

Swirly

 CRISTALLIN

NEW



SWIRLY
47 cl

Ø M = 95 mm
H = 230 mm
P = 200 g

V2820 coffret de 4



SWIRLY
35 cl

Ø M = 85 mm
H = 210 mm
P = 155 g

V2829 coffret de 4



SWIRLY
24 cl

Ø M = 70 mm
H = 235 mm
P = 155 g

V2830 coffret de 4



SWIRLY
36 cl FH

Ø M = 80 mm
H = 100 mm
P = 155 g

V2831 coffret de 4

GOBELET

BAR & TABLE



à l'honneur



FOND LOURD

● Absoluty



P 54

● Lima



P 55

● Vigne



P 56

FOND MINCE

● Macaron



P 58

● Open'Up



P 58

● Primary



P 59

STRUCTURÉ

○ Architecte



P 60

○ Lady Diamond



P 61

○ Longchamp



P 61

○ Macassar



P 63

○ Rendez-vous



P 63

○ Swirly



P 62

NEW

COLORE

● Primary Color



P 65



ABSOLUTY
45 cl FH

Ø M = 85 mm
H = 130 mm
P = 220 g

Q9217



ABSOLUTY
37 cl FH

Ø M = 80 mm
H = 120 mm
P = 190 g

Q9216



ABSOLUTY
32 cl FB

Ø M = 85 mm
H = 90 mm
P = 175 g

Q9214



ABSOLUTY
25 cl FB

Ø M = 80 mm
H = 85 mm
P = 150 g

Q9215



LIMA
45 cl FH
Ø M = 80 mm
H = 160 mm
P = 250 g
L 2356



LIMA
40 cl FH
Ø M = 80 mm
H = 135 mm
P = 240 g
L 8110



LIMA
38 cl FH
Ø M = 90 mm
H = 110 mm
P = 220 g
G 3368



LIMA
35 cl FB
Ø M = 95 mm
H = 85 mm
P = 225 g
G 3367



Lima



VIGNE
37 cl FB

Ø M = 95 mm
H = 90 mm
P = 380 g

L2370



VIGNE
31 cl FB

Ø M = 85 mm
H = 85 mm
P = 260 g

G3666



VIGNE
20 cl FB

Ø M = 75 mm
H = 75 mm
P = 220 g

G3659





VIGNE
45 cl FH
Ø M = 70 mm
H = 165 mm
P = 310 g
L 2369



VIGNE
33 cl FH
Ø M = 70 mm
H = 125 mm
P = 240 g
G 3674



VIGNE
22 cl FH
Ø M = 60 mm
H = 110 mm
P = 190 g
G 3658





Macaron

C&S **KRYSTA**

BUVANT FIN



MACARON
40 cl FH

Ø M = 90 mm
H = 105 mm
P = 140 g

N0834 ◆

Open'Up

C&S **KRYSTA**

BUVANT FIN



OPEN'UP
35 cl FH

Ø M = 80 mm
H = 120 mm
P = 150 g

U1041



OPEN'UP
38 cl FB

Ø M = 95 mm
H = 95 mm
P = 160 g

U1033



PRIMARY
44 cl FH
Ø M = 90 mm
H = 110 mm
P = 155 g
G3323



PRIMARY
40 cl FH
Ø M = 75 mm
H = 130 mm
P = 150 g
L8677



PRIMARY
36 cl FH
Ø M = 80 mm
H = 100 mm
P = 155 g
G3322



PRIMARY
27 cl FH
Ø M = 75 mm
H = 95 mm
P = 125 g
G0036

Cette ligne élégante est pratique pour les restaurants haut de gamme car destinée à tous les usages : des boissons aux cocktails, en passant par les présentations déco tendance de hors d'œuvre et de desserts.





ARCHITECTE
36 cl FH

Ø M = 85 mm
H = 130 mm
P = 390 g

V7386 coffret de 4



ARCHITECTE
32 cl FB

Ø M = 95 mm
H = 100 mm
P = 410 g

V7387 coffret de 4



ARCHITECTE
6 cl FB

Ø M = 49 mm
H = 785 mm
P = 120 g

Q4367

Lady Diamond

 CRISTALLIN



LADY DIAMOND
36 cl FH
Ø M = 70 mm
H = 130 mm
P = 400 g

L9746
V5468 coffret de 4



LADY DIAMOND
27 cl FB
Ø M = 90 mm
H = 90 mm
P = 270 g

L9747
V4485 coffret de 4

Longchamp

 CRISTALLIN



LONGCHAMP
36 cl FH
Ø M = 80 mm
H = 135 mm
P = 410 g

L9757
V7383 coffret de 4



LONGCHAMP
32 cl FB
Ø M = 56 mm
H = 95 mm
P = 290 g

L7555
V4700 coffret de 4



LONGCHAMP
4,5 cl FB HOT SHOT
Ø M = 46 mm
H = 57 mm
P = 70 g

L9756



SWIRLY
36 cl FH

Ø M = 80 mm
H = 100 mm
P = 155 g

V2831 coffret de 4



MACASSAR
36 cl FH
Ø M = 85 mm
H = 130 mm
P = 440 g
Q4340
V7376 coffret de 4



MACASSAR
32 cl FB
Ø M = 95 mm
H = 99 mm
P = 430 g
Q4337
V7377 coffret de 4



MACASSAR
6 cl FB
Ø M = 50 mm
H = 80 mm
P = 120 g
Q4342



RENDEZ-VOUS
36 cl FH
Ø M = 85 mm
H = 130 mm
P = 435 g
V7381 coffret de 4



RENDEZ-VOUS
32 cl FB
Ø M = 90 mm
H = 95 mm
P = 390 g
V7382 coffret de 4





Primary Color



PRIMARY COLOR
36 cl FH EMERALD

Ø M = 80 mm
H = 100 mm
P = 155 g

V3051



PRIMARY COLOR
36 cl FH JADE

Ø M = 80 mm
H = 100 mm
P = 155 g

V3052



PRIMARY COLOR
36 cl FH BLACK MAT

Ø M = 80 mm
H = 100 mm
P = 155 g

L9406



PRIMARY COLOR
36 cl FH WHITE MAT

Ø M = 80 mm
H = 100 mm
P = 155 g

L9407

COCKTAIL, CHAMPAGNE, BIÈRE & SPIRITUEUX



CHAMPAGNE & COCKTAIL



P 68 - 70 - 72 - 74 - 76 - 78

BIÈRE



P 80 - 82

SPIRITUEUX



P 85 - 86 - 88

COCKTAIL CHAMPAGNE
BIÈRE & SPIRITUEUX



CABERNET ABONDANT
70 cl

Ø M = 110 mm
H = 220 mm
P = 260 g

X2353 ◆



CABERNET ABONDANT
50 cl

Ø M = 100 mm
H = 200 mm
P = 220 g

X2250 ◆



CABERNET SUPRÊME
62 cl
Ø M = 95 mm
H = 240 mm
P = 260 g
X2356 ◆



CABERNET SUPRÊME
47 cl
Ø M = 85 mm
H = 215 mm
P = 220 g
X2358 ◆



CABERNET BALLON
70 cl
Ø M = 115 mm
H = 220 mm
P = 270 g
X2038



CABERNET BALLON
58 cl
Ø M = 105 mm
H = 210 mm
P = 240 g
X2059



CABERNET
24 cl GRAND CHAMPAGNE
Ø M = 70 mm
H = 235 mm
P = 145 g
X2066



CABERNET
16 cl COCKTAIL
Ø M = 70 mm
H = 225 mm
P = 145 g
X2053



CHAMPAGNE & COCKTAIL
21 cl

Ø M = 95 mm

H = 150 mm

P = 100 g

Q7785 ◆

Champagne & Cocktail 21 cl



CHAMPAGNE & COCKTAIL
44 cl
Ø M = 80 mm
H = 210 mm
P = 300 g
V3263



CHAMPAGNE & COCKTAIL
30 cl
Ø M = 120 mm
H = 190 mm
P = 220 g
N6831



CHAMPAGNE & COCKTAIL
21 cl
Ø M = 115 mm
H = 170 mm
P = 220 g
N6887



MACARON FASCINATION
30 cl
Ø M = 95 mm
H = 190 mm
P = 130 g
N6386 ♦



CHAMPAGNE & COCKTAIL
30 cl
Ø M = 120 mm
H = 170 mm
P = 175 g
N6815



CHAMPAGNE & COCKTAIL
21 cl
Ø M = 115 mm
H = 180 mm
P = 170 g
L3678



CHAMPAGNE & COCKTAIL
15 cl NICK & NORA
Ø M = 70 mm
H = 145 mm
P = 100 g
Q3702 ♦

Exaltation

C&S **KRYSTA**

EFFERVESCENCE PLUS / BUVANT FIN



≈12,5 cl

EXALTATION
35 cl

Ø M = 80 mm
H = 235 mm
P = 155 g

Q0818



≈10 cl

EXALTATION
30 cl

Ø M = 80 mm
H = 210 mm
P = 150 g

Q1151

Q9945 coffret de 2



EXALTATION
47 cl

Ø M = 90 mm
H = 225 mm
P = 185 g

V6190

V6831 coffret de 2



MACARON
60 cl
Ø M = 105 mm
H = 235 mm
P = 195 g
L9414 ◆



MACARON
40 cl
Ø M = 95 mm
H = 200 mm
P = 135 g
L9267 ◆



MACARON
30 cl
Ø M = 85 mm
H = 200 mm
P = 130 g
L9348 ◆

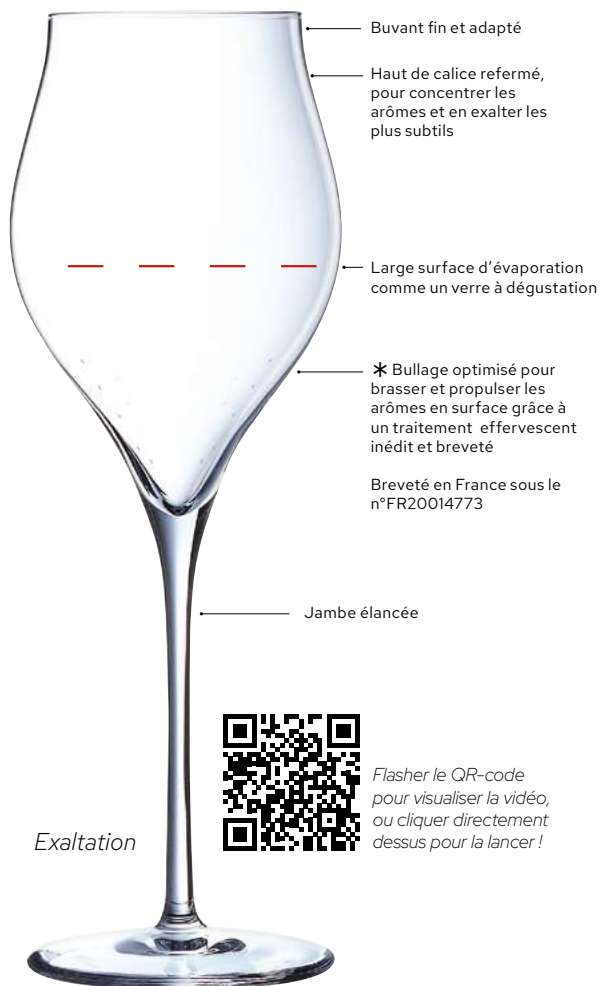

Open'Up



OPEN'UP
20 cl
Ø M = 75 mm
H = 235 mm
P = 165 g
U1051



REVEAL'UP

21 cl

Ø M = 70 mm

H = 235 mm

P = 155 g

J8907



REVEAL'UP

40 cl SOFT

Ø M = 90 mm

H = 230 mm

P = 195 g

J8743



REVEAL'UP

30 cl SOFT

Ø M = 85 mm

H = 220 mm

P = 140 g

J8908

Sensation Exalt

C&S **KRYSTA**

EFFERVESCENCE PLUS / BUVANT FIN



SENSATION EXALT
19 cl
Ø M = 70 mm
H = 210 mm
P = 170 g
X2048

Séquence

C&S **KRYSTA**

EFFERVESCENCE PLUS / BUVANT FIN



SÉQUENCE
24 cl IMPERIALE
Ø M = 70 mm
H = 235 mm
P = 155 g
P3787



SÉQUENCE
17 cl
Ø M = 55 mm
H = 210 mm
P = 135 g
L9947



Reveal'Up

COCKTAIL CHAMPAGNE
BIÈRE & SPIRITUEUX

Sublym

C&S KRYSTA

* EFFERVESCENCE PLUS

BUVANT FIN



SUBLYM
60 cl BALLON
Ø M = 110 mm
H = 230 mm
P = 210 g
N4742



SUBLYM
21 cl *
Ø M = 65 mm
H = 240 mm
P = 140 g
L2762

de
petit plat.
cialworking,
la journée l
la journée l
carte des cocktails
du bordelais.
ssiques du bordelais.
beneath the Atrium's
avouring tasty fayre, or
ng table - at Madame B.
With friends or family,
great Bordeaux

Symétrie



SYMÉTRIE
58 cl

Ø M = 105 mm
H = 210 mm
P = 240 g

Q8707



SYMÉTRIE
21 cl

Ø M = 115 mm
H = 180 mm
P = 170 g

V1171



SYMÉTRIE
21 cl

Ø M = 65 mm
H = 240 mm
P = 140 g

V2697



SYMÉTRIE
16 cl

Ø M = 65 mm
H = 200 mm
P = 130 g

V1375



LADY DIAMOND
15 cl
Ø M = 75 mm
H = 230 mm
P = 290 g
L9742
V8228 coffret de 4



NEW

LADY DIAMOND
23 cl
Ø M = 100 mm
H = 180 mm
P = 300 g
X1718 coffret de 4

Longchamp

 CRISTALLIN



LONGCHAMP
14 cl

Ø M = 65 mm
H = 205 mm
P = 270 g

L7553

V4705 coffret de 4

Macassar

 CRISTALLIN



MACASSAR
17 cl

Ø M = 60 mm
H = 235 mm
P = 210 g

Q4335

V7373 coffret de 4

Rendez-vous

 CRISTALLIN



RENDEZ-VOUS
17 cl

Ø M = 65 mm
H = 220 mm
P = 260 g

V7378 coffret de 4

Swirly

 CRISTALLIN



SWIRLY
24 cl

Ø M = 70 mm
H = 235 mm
P = 155 g

V2830 coffret de 4



BEER EXPERT
43 cl

Ø M = 110 mm

H = 195 mm

P = 210 g

X3080

Cabernet Vins jeunes

C&S **KRYSTA**
BUVANT FIN



≈15 cl

CABERNET VINS JEUNES
47 cl

Ø M = 100 mm
H = 215 mm
P = 190 g

X1720

Open'Up

C&S **KRYSTA**
BUVANT FIN



≈ 9,5 cl

OPEN'UP
47 cl SOFT

Ø M = 105 mm
H = 225 mm
P = 210 g

U1012

Reveal'Up

C&S **KRYSTA**
EFFERVESCENCE PLUS/BUVANT FIN

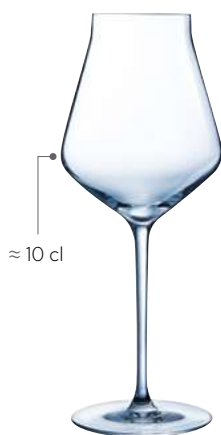

≈ 10 cl

REVEAL'UP
40 cl SOFT

Ø M = 90 mm
H = 230 mm
P = 195 g

J8743

Sublym

C&S **KRYSTA**
BUVANT FIN



SUBLYM
45 cl

Ø M = 90 mm
H = 250 mm
P = 210 g

N1739

Séquence

C&S KRYSTA

BUVANT FIN



SÉQUENCE
37 cl

Ø M = 80 mm
H = 150 mm
P = 130 g
P0089

Lima

C&S KRYSTA

BUVANT FIN



LIMA
45 cl FH

Ø M = 80 mm
H = 160 mm
P = 250 g
L2356

Vigne

C&S KRYSTA

BUVANT FIN



VIGNE
45 cl FH

Ø M = 70 mm
H = 165 mm
P = 310 g
L2369

Reveal'Up Soft

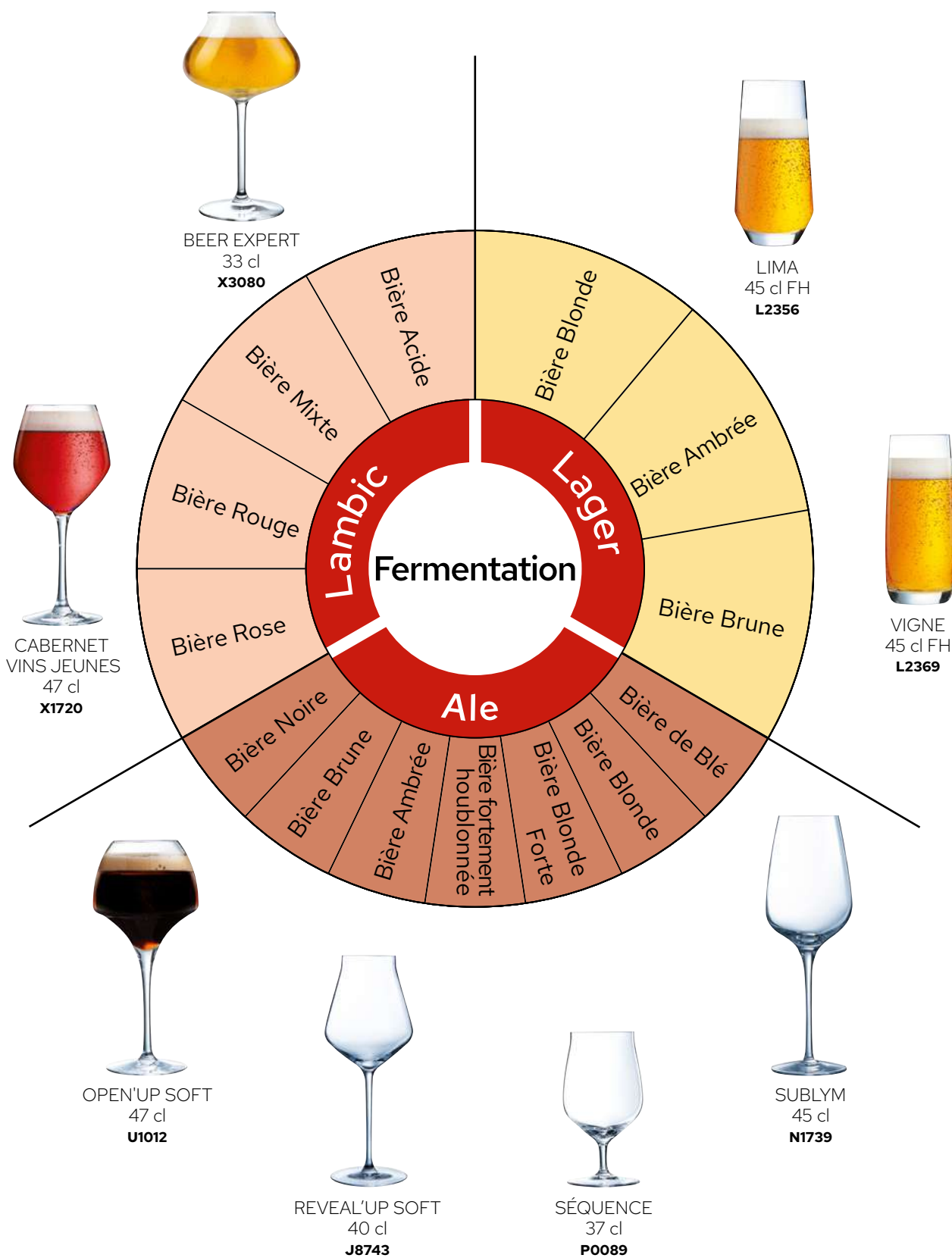

Lambic : Bière de fermentation spontanée

Lager : Bière de fermentation basse (basse température)

Ale : Bière de fermentation haute (haute température)



Chet & Stammeler

Open'Up Spirit





≈ 10 cl

OPEN'UP SPIRIT
39 cl ARDENT

Ø M = 105 mm
H = 130 mm
P = 170 g

U1059 ◆



≈ 7 cl

OPEN'UP SPIRIT
30 cl WARM

Ø M = 100 mm
H = 85 mm
P = 155 g

U1032

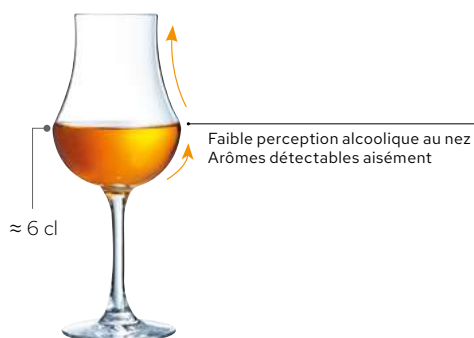

≈ 6 cl

Faible perception alcoolique au nez
Arômes détectables aisément

OPEN'UP SPIRIT
16,5 cl AMBIENT

Ø M = 70 mm
H = 170 mm
P = 105 g

U1062 ◆



SPIRITS
6,5 cl CORDIAL
Ø M = 56 mm
H = 160 mm
P = 105 g
N 8213 ◆



SPIRITS
11 cl CORDIAL
Ø M = 60 mm
H = 200 mm
P = 90 g
N 8212 ◆



SPIRITS
12 cl SHERRY
Ø M = 60 mm
H = 190 mm
P = 80 g
N 8209 ◆



SPIRITS
10 cl GRAPPA
Ø M = 65 mm
H = 180 mm
P = 95 g
N 8211 ◆



SPIRITS
17 cl RHUM
Ø M = 75 mm
H = 130 mm
P = 105 g
N6374 ◆



SPIRITS
70 cl COGNAC
Ø M = 115 mm
H = 165 mm
P = 200 g
N8172 ◆

Séquence



SÉQUENCE
21 cl PORTO
Ø M = 65 mm
H = 190 mm
P = 115 g
N9696 ◆



Lima

C&S KRYSTA

BUVANT FIN



LIMA
35 cl FB
Ø M = 95 mm
H = 85 mm
P = 230 g
G3367

Vigne

C&S KRYSTA

BUVANT FIN



VIGNE
38 cl FB
Ø M = 95 mm
H = 90 mm
P = 380 g
L2370



VIGNE
31 cl FB
Ø M = 85 mm
H = 85 mm
P = 260 g
G3666



VIGNE
20 cl FB
Ø M = 75 mm
H = 75 mm
P = 220 g
G3659

Architecte

 CRISTALLIN



ARCHITECTE
32 cl FB

Ø M = 95 mm
H = 100 mm
P = 410 g

V7387 coffret de 4



ARCHITECTE
6 cl FB

Ø M = 49 mm
H = 78,5 mm
P = 120 g

Q4367

Longchamp

 CRISTALLIN



LONGCHAMP
32 cl FB

Ø M = 56 mm
H = 95 mm
P = 290 g

L7555

V4700 coffret de 4



LONGCHAMP
4,5 cl FB HOT SHOT

Ø M = 26 mm
H = 57 mm
P = 70 g

L9756

Macassar

 CRISTALLIN



MACASSAR
32 cl FB

Ø M = 95 mm
H = 100 mm
P = 430 g

Q4337

V7377 coffret de 4



MACASSAR
6 cl FB

Ø M = 50 mm
H = 80 mm
P = 120 g

Q4342

Rendez-vous

 CRISTALLIN



RENDEZ-VOUS
32 cl FB

Ø M = 90 mm
H = 95 mm
P = 390 g

V7382

V7382 coffret de 4

CARAFE



Les dépôts des vins matures doivent être éliminés par le sommelier afin de profiter pleinement des trésors du vin.
Hommage aux vins matures et aux sommeliers !

● Explore



P 92

● Abondance **NEW**

P 92

Augmenter la qualité des vins jeunes en accélérant leur maturation est un geste quotidien chez le sommelier.

Aérer un vin en carafe est une occasion pour le sommelier d'engager la conversation sur les expériences gustatives qu'il veut faire vivre à ses convives.

● Macaron



P 93

● Opening



P 93

● Open'Up



P 93



Explore

C&S **KRYSTA**

SOUFFLÉ BOUCHE / TRAITEMENT ANTI-GOUTTE



EXPLORE
1,3 L

Ø M = 145 mm

H = 325 mm

P = 800 g

V4667 ◆

Abondance

C&S **KRYSTA**

NEW

SOUFFLÉ BOUCHE



ABONDANCE
1,6 L

Ø M = 190 mm

H = 235 mm

P = 700 g

V9689 ◆

Abondance

Macaron

C&S **KRYSTA**

SOUFFLÉ BOUCHE / TRAITEMENT ANTI-GOUTTE



MACARON
2 L
Ø M = 165 mm
H = 310 mm
P = 700 g
V6503 ◆

Opening

C&S **KRYSTA**

SOUFFLÉ BOUCHE / TRAITEMENT ANTI-GOUTTE



OPENING
0,9 L
Ø M = 210 mm
H = 240 mm
P = 660 g
R0020 ◆

Open'Up

C&S **KRYSTA**

SOUFFLÉ BOUCHE / TRAITEMENT ANTI-GOUTTE



OPEN'UP
1,4 L
Ø M = 145 mm
H = 315 mm
P = 610 g
D6653 ◆

INFORMATION
PRODUIT



COLLECTION	RÉF	CODE BARRE ARTICLE	CODE BARRE EMBALLAGE
ABONDANCE	V9689	0883314027587	0883314027587
ABSOLUTY	Q9217	0883314907681	0883314907735
	Q9216	0883314907674	0883314907728
	Q9214	0883314907650	0883314907704
	Q9215	0883314907667	0883314907711
ARCHITECTE	V7386		0883314988291
	V7387		0883314988307
BEER EXPERT	X3080	0883314112955	0883314112979
CABERNET	X2036	0026102259023	0026102980217
	X2054	0026102259078	0026102469514
	X2033	0026102259191	0026102469668
	X2055	0026102259207	0026102469774
	X2056	0026102260012	0026102469798
	X2038	0026102259290	0026102469941
	X2067	0026102470176	0026102470183
	X2050	0026102259382	0026102470213
	X2059	0026102470268	0026102470275
	X2053	0026102259894	0026102466070
	X2064	0026102259412	0026102534694
	X2049	0026102259801	0026102879184
	X2066	0026102259818	0026102879191
	X2360	0883314339895	0883314084474
	X2356	0883314505009	0883314504996
	X2358	0883314505023	0883314505016
	X2353	0883314505047	0883314505030
	X2250	0883314510775	0883314505054
	X2065	0883314340044	0883314189322
	X2057	0883314340112	0883314189353
CABERNET VINS JEUNES	X2034	0883314132083	0883314050257
	X2035	0883314340129	0883314050264
	X1720	0883314132090	0883314050271

COLLECTION	RÉF	CODE BARRE ARTICLE	CODE BARRE EMBALLAGE
CHAMPAGNE & COCKTAIL	N6815	0883314290745	0883314290769
	N6831	0883314259520	0883314670776
	V3263	0883314684469	0883314684476
	N6887	0883314290868	0883314670950
	L3678	0883314518498	0883314518504
	Q7785	0883314891942	0883314891935
	Q3702	0883314848694	0883314848700
DISTINCTION	Q9064	0883314905984	0883314905991
	Q9062	0883314905946	0883314905953
	Q8990	0883314905120	0883314905137
	Q9080	0883314906226	0883314906233
ÉVIDENCE	X2068	0883314943429	0883314943436
	X2042	0883314943405	0883314943412
	X2058	0883314943443	0883314943450
	X2063	0883314943467	0883314943474
EXALTATION	V6719	0883314984781	0883314984798
	V6189	0883314975819	0883314975826
	V6190	0883314975833	0883314975840
	V6191	0883314975857	0883314975864
	Q1151	0883314823677	0883314823684
	Q9945		0883314915655
	Q0818	0883314819748	0883314819755
EXPLORE	V4667	0883314961614	0883314961614
GALEA	X2712	0883314101782	0883314101799
	X2713	0883314101805	0883314101812
	X2495	0883314101492	0883314101843
	X2714	0883314101829	0883314101843
LADY DIAMOND ...	L9742	0883314591538	0883314591521
	V8228		0883314959857
	L9743	0883314591552	0883314591545
	V4483		0883314959864

COLLECTION	RÉF	CODE BARRE ARTICLE	CODE BARRE EMBALLAGE	COLLECTION	RÉF	CODE BARRE ARTICLE	CODE BARRE EMBALLAGE
... LADY DIAMOND	L9744	0883314591576	0883314591569	... MACASSAR	V7373		0883314988147
	V4484		0883314959871		Q4331	0883314552720	0883314552737
	L9747	883314591637	0883314 591620		V7374		0883314988154
	V4485		0883314959888		Q4346	0883314552706	0883314552690
	L9746	0883314591613	0883314591606		V7375		0883314988161
	V5468		0883314968293		Q4340	0883314552775	0883314552782
	X1718		0883314075533		V7376		0883314988178
					Q4337	0883314552942	0883314552959
LIMA	G3367	0026102131817	0026102857069	V7377		0883314988185	
	G3368	0026102131770	0026102857045	MYLLA	X2716	0883314101881	0883314101898
	L2356	0883314503401	0883314503418		X2717	0883314101911	0883314101928
	L8110	0883314571769	0883314571776		X2500	0883314101515	0883314101522
LONGCHAMP	L7553	0883314564280	0883314564273	X2718	0883314101935	0883314101966	
	V4705		0883314961881	OPEN'UP	D6653	0026102256138	0026102256138
	L7550	0883314564235	0883314564228		U1008	0026102274576	0026102293355
	V4704		0883314961874		U1010	0026102900246	0026102878521
	L7552	0883314564266	883314564259		U1011	0026102900635	0026102879238
	V4702		0883314961850		U1012	0026102900840	0026102878552
	L7555	0883314564327	0883314564310		U1013	0026102900451	0026102878545
	V4700		0883314961836		U1033	0883314028461	0883314028294
	L9757	0883314591835	0883314591828		U1041	0883314258899	0883314256017
	V7383		0883314988253		U1051	0026102880623	0026102878514
	L9754	0883314591774	0883314591767		OPEN'UP SPIRIT	U1032	0883314083361
	L9756	0883314591811	0883314591804	U1059		0883314105308	0883314119749
				U1062		0883314083255	0883314084238
MACARON	L9267	0883314586763	0883314586770	OPENING	R0020	0026102892084	0026102892084
	L9348	0883314586824	0883314586831	PRIMARY	G0036	0026102259511	0026102116524
	L9412	0883314586787	0883314586794		G3322	0026102259610	0026102116203
	L9414	0883314586800	0883314586817		G3323	0026102259306	0026102116142
	N0834	0883314605143	0883314605150	L8677	0883314578218	0883314578225	
	V6503	0883314606751	0883314606751	PRIMARY COLOR ...	L9406	0883314586633	0883314586640
MACARON FASCINATION	N6386	0883314665536					
MACASSAR ...	Q4335	0883314552676	0883314552683				

COLLECTION	RÉF	CODE BARRE ARTICLE	CODE BARRE EMBALLAGE
... PRIMARY COLOR	L 9407	0883314586657	0883314586664
	V3051	0883314946413	0883314946420
	V3052	0883314946444	0883314946482
RENDEZ-VOUS	V7378		0883314988192
	V7379		0883314988208
	V7380		0883314988215
	V7381		0883314988239
	V7382		0883314988246
REVEAL'UP	J8742	0883314465655	0883314465662
	J8743	0883314465600	0883314465617
	J8907	0883314465563	0883314465570
	J8908	0883314465587	0883314465594
	J9014	0883314465679	0883314465686
	N1738	0883314465624	0883314465631
SENSATION EXALT	X2047	0883314340075	0883314118520
	X1722	0883314340099	0883314118537
	X2046	0883314340082	0883314118544
	X2040	0883314339963	0883314118551
	X2048	0883314339970	0883314118568
SÉQUENCE	L 9947	0883314594379	0883314594386
	L 9948	0883314594393	0883314594409
	L 9949	0883314594416	0883314594423
	L 9950	0883314594430	0883314594447
	L 9951	0883314594454	0883314594461
	N9696	0883314701456	0883314701463
	N9710	0883314701630	0883314701647
	N9711	0883314701654	0883314701661
	P0089	0883314704952	0883314704969
	P3787	0883314744842	0883314744859
SPIRITS ...	N6374	0883314689570	0883314689587
	N8172	0883314684094	0883314684100

COLLECTION	RÉF	CODE BARRE ARTICLE	CODE BARRE EMBALLAGE
...SPIRITS	N8209	0883314684353	0883314684360
	N 8211	0883314684384	0883314684391
	N 8212	0883314684407	0883314684414
	N 8213	0883314684421	0883314684438
SUBLYM	L 2609	0883314508253	0883314508246
	L 2761	0883314508239	0883314508222
	L 2762	0883314508277	0883314508260
	N1739	0883314508215	0883314508208
	V3604	0883314508185	0883314508178
	N5368	0883314661484	0883314661491
SWIRLY	V2829	0883314943528	0883314943535
	V2820		0883314943382
	V2830		0883314943559
	V2831		0883314943573
SYMÉTRIE	Q8707	0883314902174	0883314902181
	V2696	0883314941982	0883314941999
	V0391	0883314920321	0883314920338
	V1483	0883314931549	0883314931556
	V1171	0883314931730	0883314931747
	V2697	0883314942002	0883314942019
	V1375	0883314931570	0883314931587
VIGNE	G 3658	0026102259269	0026102466988
	G 3659	0026102259221	0026102467534
	G 3666	0026102258941	0026102472149
	G 3674	0026102258927	0026102468050
	L 2369	0883314503678	0883314503685
	L 2370	0883314503692	0883314503715
VIN AU VERRE	X3045	0883314418415	0883314526875
	X3042	0883314795837	0883314795844
	X3043	0883314800074	0883314800081

CRISTALLIN

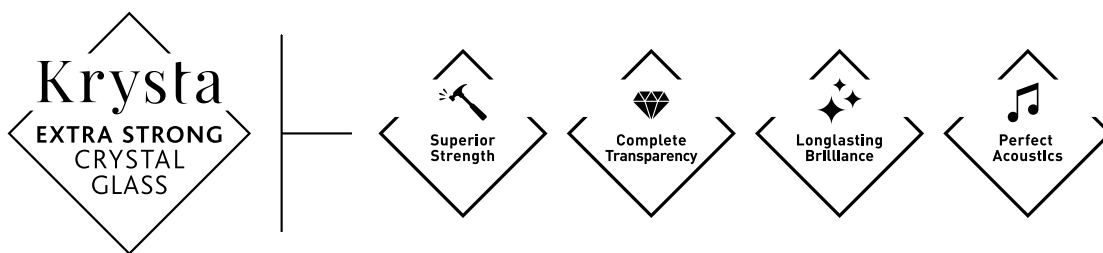

Les exigences des professionnels de la gastronomie vont enfin profiter aux particuliers.

Perfection, raffinement, mise en table de grande élégance illumineront les repas à la maison grâce à des produits fins, légers et extrêmement transparents.

Cette verrerie de **haute résistance aux chocs et aux détergents** de vos lave-vaisselle supportera une **utilisation intensive** que nous vous invitons à copier sur les restaurateurs.

Pour répondre à ce **double défi d'excellence esthétique et de résistance**, le centre d'Arc, présente une nouvelle génération de cristallin sans plomb : **Krysta™, le cristallin aux performances d'exception.**



RÉSISTANCE SUPÉRIEURE

Le centre de recherche Arc a élaboré un matériau cristallin, le Krysta™, qui allie une **résistance supérieure à une finesse remarquable des produits.**

Le buvant : pour une épaisseur d'1,1 mm, KRYSTA™ est 30% plus résistant que les verres cristallin de l'ensemble du marché.

- Des verres plus résistants, que l'on sort à toutes occasions.



TRANSPARENCE ABSOLUE

Krysta™ est un des cristallins **le plus pur et le plus transparent** du marché.

La parfaite maîtrise de sa composition, la qualité du sable utilisé et la fusion à très haute température assurent au Krysta™ une transparence parfaite.

- Des tables sublimes par l'éclat du Krysta™.
- La robe de chaque vin respectée à la perfection.



BRILLANCE DURABLE

Krysta™ possède une extrême brillance durable dans le temps.

Après 2000 cycles en lave-vaisselle ménager, Krysta™ **conserve sa brillance et sa transparence originelles.**

- Des verres qui apportent leur touche unique de brillance sur vos tables.
- Des services à l'éclat durable que vous conserverez longtemps.

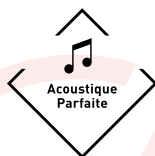

ACOUSTIQUE PARFAITE

Grâce à sa formulation exclusive, Krysta™ produit **un son clair et pur** dans la tradition sonore des meilleurs verres en cristal.

- La séduction du Krysta™ : un éclat unique associé à une sonorité singulière pour un plaisir sensoriel raffiné.



KRYSTA

Le verre en cristal aux performances exceptionnelles

Depuis **plus de 200 ans**, Chef & Sommelier™ repousse les limites de l'art verrier. Aujourd'hui, la marque **ouvre un nouveau chapitre** avec une évolution majeure de son matériau signature : le Krysta™.

Ce cristallin, déjà reconnu pour sa résistance et sa brillance exceptionnelles, atteint désormais **une finesse inégalée**. Grâce à un procédé de fabrication de pointe, le **Krysta EXTRA-FIN** permet de créer des **verres aux paraisons, buvants et jambes d'une finesse et d'un raffinement incomparables**.

Cette prouesse technique n'a qu'un seul objectif : **sublimier l'expérience de dégustation** et amplifier chaque nuance du vin grâce à la sensation délicate du verre.

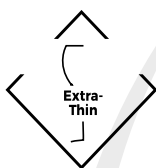
**40%**

Buvants et jambes affinés en moyenne de 40 % par rapport à nos collections classiques.

**TRANSPARENCE ABSOLUE**

Krysta™ est un des cristallins **le plus pur et le plus transparent** du marché. La parfaite maîtrise de sa composition, la qualité du sable utilisé et la fusion à très haute température assurent au Krysta™ une transparence parfaite.

- **Des tables sublimes par l'éclat du Krysta™.**
- **La robe de chaque vin respectée à la perfection.**

**BRILLANCE DURABLE**

Krysta™ possède une extrême brillance durable dans le temps. Après 2000 cycles en lave-vaisselle ménager, Krysta™ **conserve sa brillance et sa transparence originelles**.

- **Des verres qui apportent leur touche unique de brillance sur vos tables.**
- **Des services à l'éclat durable que vous conserverez longtemps.**

**ACOUSTIQUE PARFAITE**

Grâce à sa formulation exclusive, Krysta™ produit **un son clair et pur** dans la tradition sonore des meilleurs verres en cristal.

- **La séduction du Krysta™ : un éclat unique associé à une sonorité singulière pour un plaisir sensoriel raffiné.**

Conseil pour laver mes verres...

A la machine, c'est recommandé ! En effet, tous nos verres sont en :

Je fais...

- 1 Je privilégie l'utilisation des produits « CLASSIC », en pastille, en gel ou en poudre. Je veille à ne pas surdoser de produit.
- 2 Je règle le lave-vaisselle en enregistrant la dureté de mon eau. Cette valeur me sera transmise par la mairie de mon domicile. (TH : 5 à 7°f en moyenne).
- 3 Je surveille que le sel régénérant et le liquide de rinçage (de même marque que la pastille) soient toujours disponibles.
- 4 Dans mon lave-vaisselle...

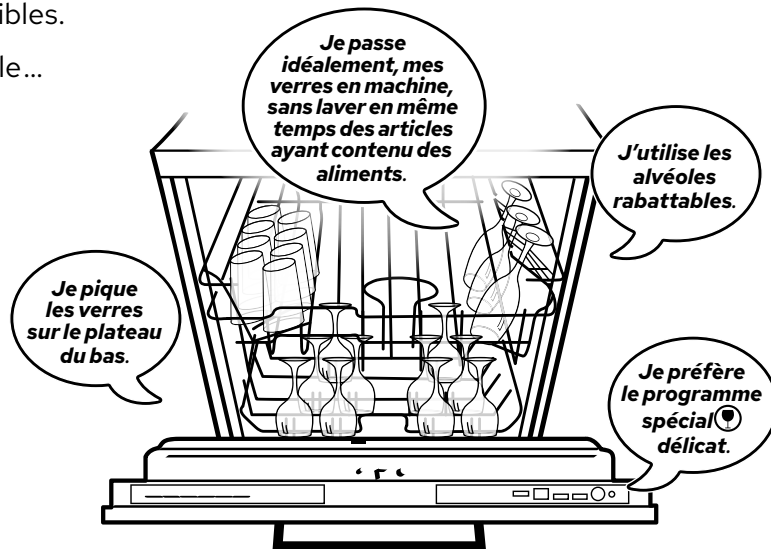
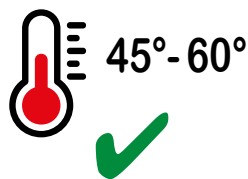
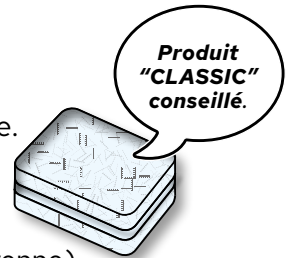

Conseils pour ranger mes verres...

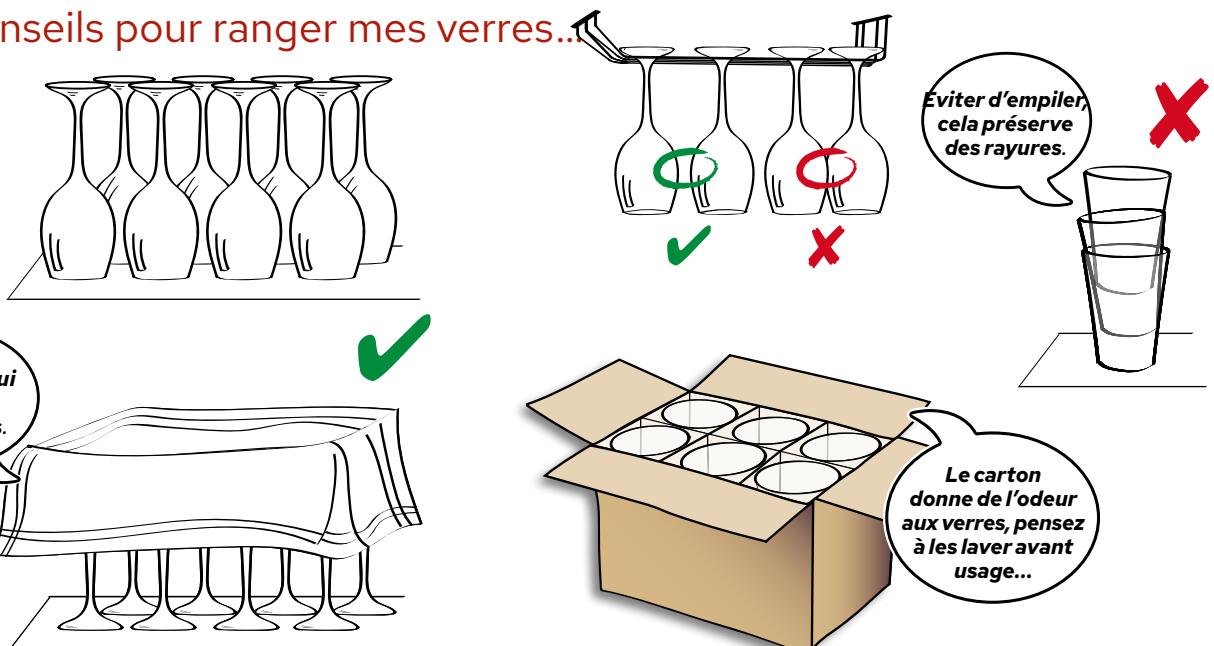

Astuces...



Je ne fais pas...

- 1 Si j'utilise des pastilles « TOUT-EN-UN », « ALL-IN-ONE », je n'ajoute pas de sel régénérant ni de produit de rinçage, même si le témoin reste allumé !
- 2 Je n'utilise pas des produits « Tout-en-un » si j'ai un adoucisseur, cela blanchirait mes verres de façon irrémédiable.
- 3 J'évite les produits « Tout-en-un » dans les régions très calcaires car la quantité de sel ne sera pas assez importante, mes verres risqueraient d'avoir des dépôts de calcaire.
- 4 Dans mon lave-vaisselle...

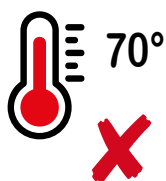

Pour éviter les dépôts irisés sur mes verres, je ne les passe pas avec des articles ménagers en alu, des couverts comportant des rivets, des articles en métal argenté.

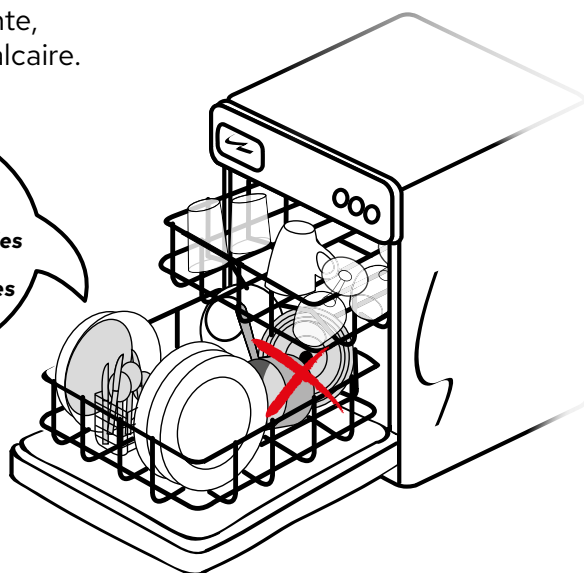

Si j'achète une taille unique, je choisis...

Verre le plus polyvalent, y compris pour les vins effervescents.



47 à 35cl

Si j'utilise un verre tous les jours, lequel je choisis ?

Pro Tasting : parfait pour des vins jeunes rouges, rosés ou blancs.
Son pied court lui permet de passer sur le plateau supérieur de mon lave-vaisselle.



— CRÉATEUR D'EXPÉRIENCES —

CRÉATEUR D'EXPÉRIENCES
COLLECTION VERRERIE 2026

